

ES22 2D Barcode Scanner Module

Integrated Manual

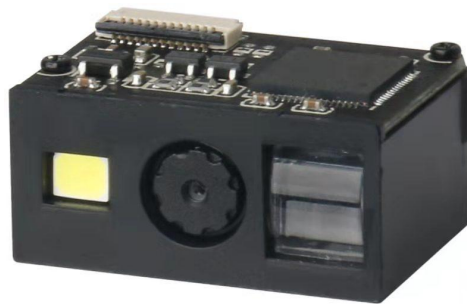

Specification:

Communication mode	USB (USB-KBW, USB-COM), RS-232, TTL-232
Image Sensor	CMOS
Pixel	300,000 pixels
Resolution	≥4mil/0.1mm (PCS90%,CODE 39)
Decoding speed	25CM/S
Reading mode	Manual reading, induction reading, continuous reading, command control
Prompt method	LED , Buzzer (external circuit)
Field of view	36° * 28°
Reading angle	Test Conditions: CODE39,10mil/0.25mm,PCS90%
	Rotation Roll: ±360°, Pitch: ±50°, Skew: ±50°
Print contrast	≥25%
Environmental illumination degree	Dark environment, indoor natural light,
Symbologies	1D: UPC-A, UPC-E, EAN-8, EAN-13, Code 128, Code 39, Code 93, Interleaved 2 of 5, Matrix 2 of 5, Industrial 2 of 5(Straight 25), Standard 2 of 5(IATA25), Codabar(NW-7), etc. 2D: QR Code, Micro QR Code, Data Matrix, PDF417, etc.



Body weight	≈3.0g
Physical dimension	14.6mm(L) * 22mm(W) * 11.3mm(H)
Flat cable length	5CM(FFC single-sided cable)
Interface Type	FFC 12PIN Pitch 0.5
Operating Voltage	DC 3.3V
Current current	180mA (Average Work) , 60mA(Standby)
Operating temperature	-20℃ to 50℃
Storage temperature	-40℃ to 60℃
Working humidity	5% to 95% (No condensation)
Transport vibration test	10H@125RPM
FFC cable	12Pin Pitch 0.5 5CM on the same side.
Development	Used to connect modules and cables, with output functions of board (optional) different interfaces, and scan prompt function.
Cable (optional)	Used to connect the development board and the communication host, with different interface cables optional.

(1).External View: The following picture shows the appearance of ES22, with MCU, FFC power socket and other electronic components on the top. The front part contains a floodlight, a aiming lamp and an CMOS camera that is used to scan barcodes, and there are two M1.6 fixing holes at the bottom to fix the ES22 to other devices.

Noted:

1. In order to maintain the excellent reading performance of the ES22's barcode scanner, please keep the product clean;
2. Please use a soft cloth to clean the window. Do not spray any liquid on the window.

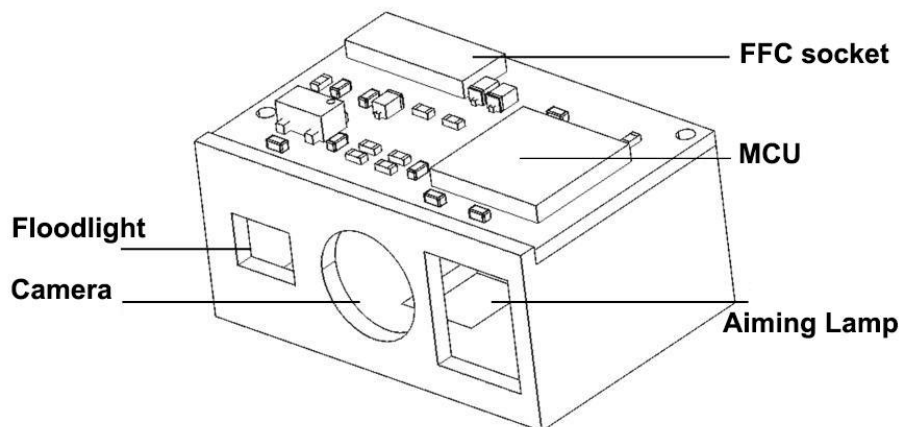

(2).12PIN FFC Interface: The physical interface of ES22 is a 12PIN FFC interface, which can be multiplexed into two communication forms: TTL-232/RS-232 communication form and USB communication form. The figure below is a schematic diagram of connecting the cable to the data interface.

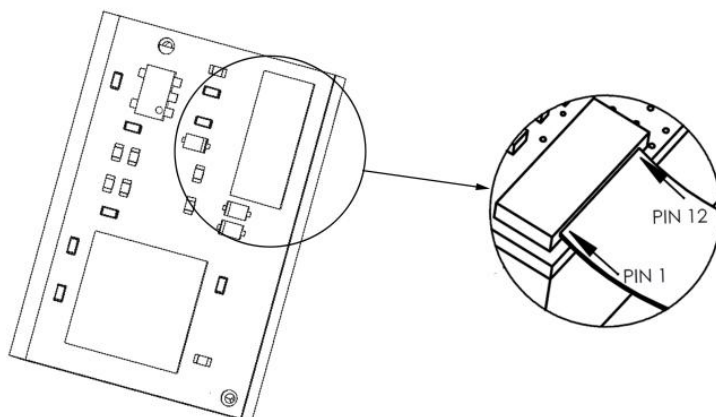

(3).FFC Wiring Diagram:

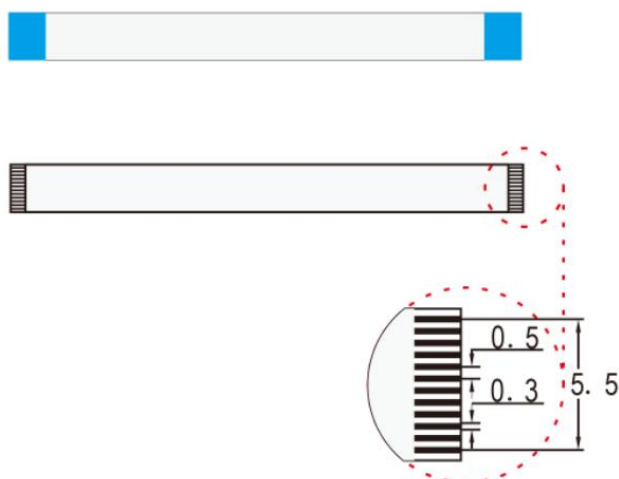

(4).Interface definition: The ES22 uses a 12PIN pitch 0.5 data interface. The following table lists the names and signal descriptions of each PIN of the 12PIN connector.

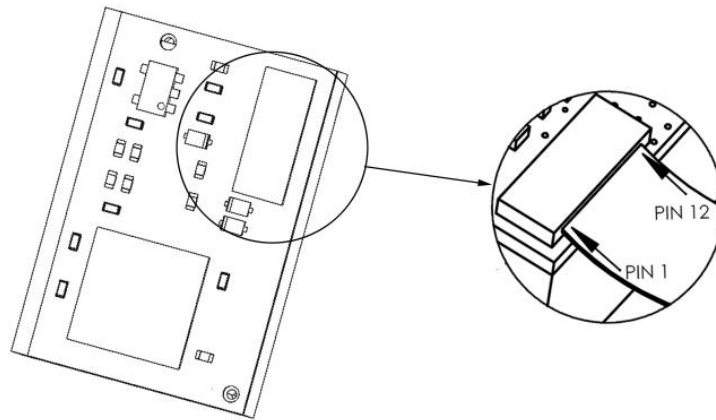

PIN#	Signal	Type	Definition
1	NC	-	NC
2	VIN	P	Power input DC 3.3V±5%
3	GND	P	Power ground
4	UART_RX	input	TTL-RS232 receiving, 3.3V level
5	UART_TX	Output	TTL-RS232 transmission, 3.3V level
6	USB_DM/D-	Input/Output	USB_D- signal
7	USB_DP/D+	Input/Output	USB_D+ signal
8	NC	-	NC
9	BEEP	Output	Passive buzzer output signal, idle low level
10	LED	Output	Decoding successful prompt output signal, idle low level
11	NC	-	NC
12	TRIG	input	Low level trigger, keep low level for more than 20ms to trigger code reading (external pull-up resistor is required)

(5).Reading Perspective:

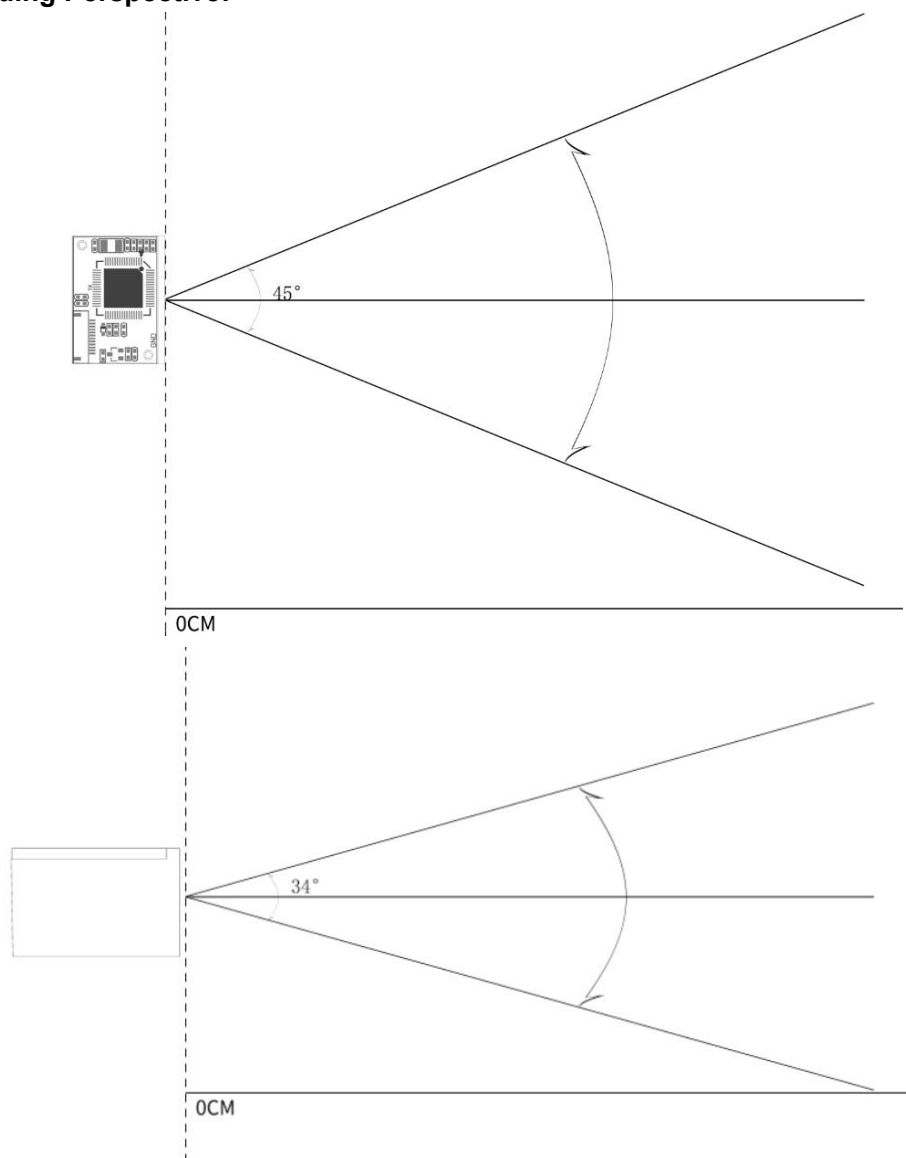

Typical Depth of Field:

Barcode Type	Barcode Density	Recent	Farthest
Code 39	0.1mm(4mil)	60mm	100mm
Code 39	0.5mm(20mil)	60mm	300mm
UPC/EAN	0.33mm(13mil)	50mm	230mm
QR Code	20.0mil	25mm	210mm

Data Matrix	10mil	50mm	110mm
PDF 417	6.88mil	50mm	120mm

Test conditions: room temperature 25°C, environmental illumination 200LUX, PCS=0.9

Note: Depending on the size of the bar code type, the actual reading distance may be farther.

(6).Structure Size:

The ES22 embedded two-dimensional image module adopts an integrated design. When using the ES22 for integrated applications, you can refer to the following physical size specifications.

Unit: mm

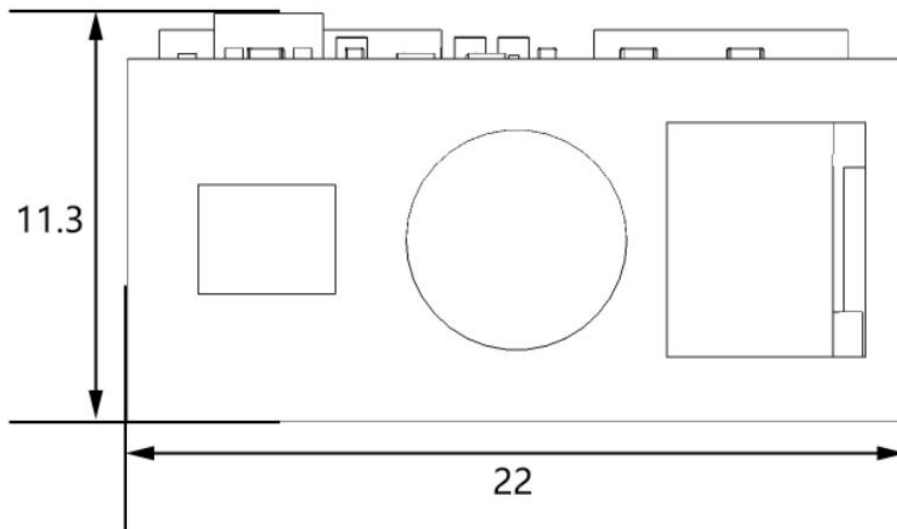

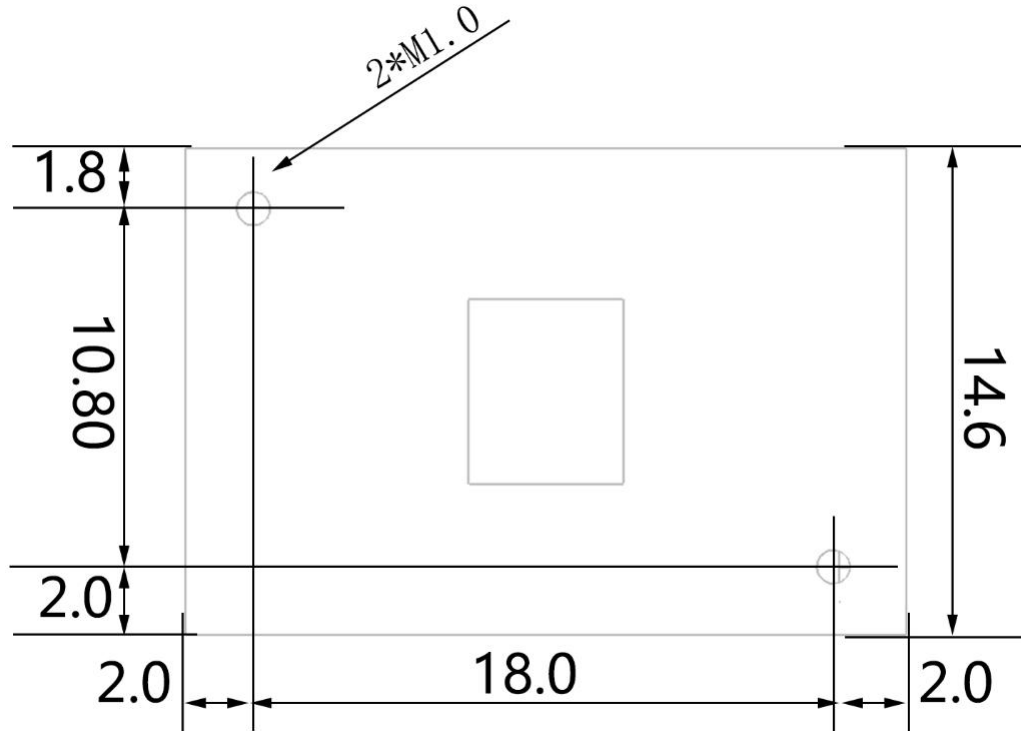

(7).Trigger Control Interface:

TRIF PIN(PIN 12)means triggering when low level is input, and when high level, it means triggering stop (or release). ES22 starts to read after receiving the trigger, and will output decoded information after successful reading, and then wait for the trigger signal to stop (or release). During the triggering process, the trigger signal stops (or releases), and the reading process is terminated.

A new reading process needs to regenerate the trigger signal.

The reading process needs to go through the steps of image acquisition, barcode recognition and interpretation. It is recommended that the interval between the two trigger signals should not be less than 50ms. Refer to the following trigger circuit design:

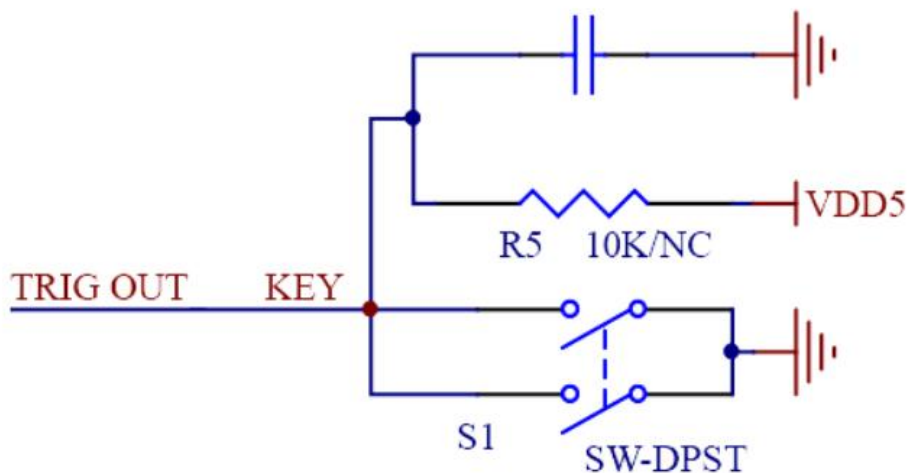

(8).Buzzer Signal:

In ES22, the BEEP PIN(PIN 9) uses PWM mode to provide Beeper signal output. Start at ES22, in the case of successful reading, the PWM signal will be output on the BEEP pin according to the setting. This signal output can drive the buzzer to emit a warning sound through an external supporting circuit. The load capacity of the BEEP pin is limited, so it is not possible to directly drive the buzzer to sound, so as not to damage the chip on the ES22. Refer to the buzzer drive circuit as shown in the figure below:

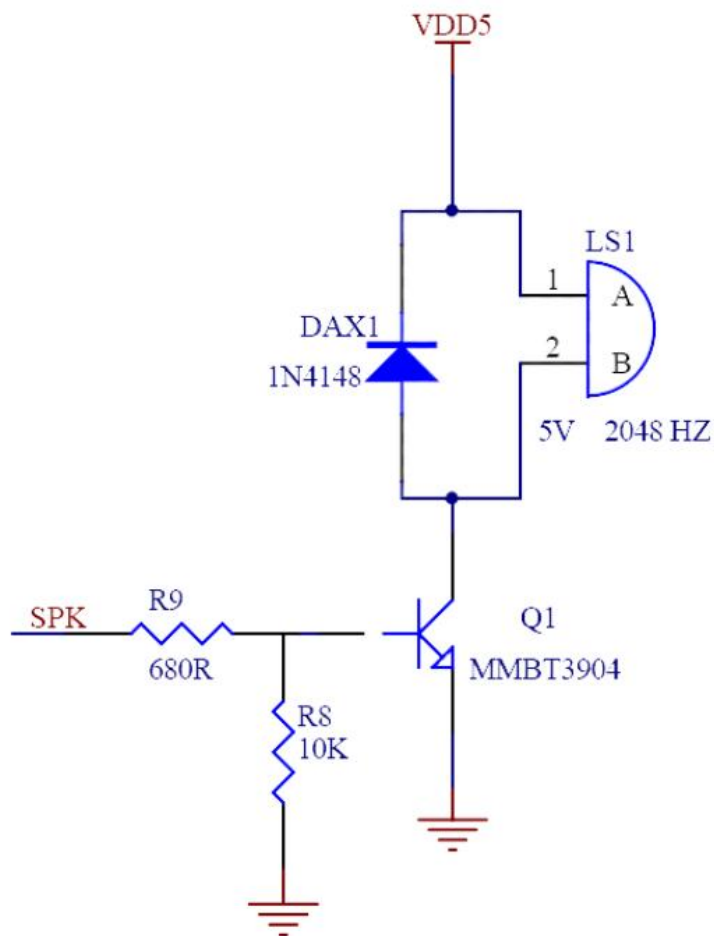

(9).Decode LED Signal:

The LED(PIN 10) pin of ES22 can provide a level prompt signal when decoding is successful, and is usually used as an input control signal for external decoding LED prompt. When the decoding is successful, the LED pin will output a high-level pulse and eventually return to low-level.

The load capacity of the LED signal output pin is limited, and it is not possible to directly drive the light-emitting diode, and a supporting light-emitting diode drive circuit is required. Refer to the following figure for the supporting LED prompt driving circuit used:

